



Pro *for* Pros

MEDICAL CABINET SYSTEM



Aeolus International Pet Products
www.AEOLUSpet.com
www.KANISTARvet.com



Aeolus International Pet Products
www.AEOLUSpet.com
www.KANISTARvet.com

MEDICAL CABINET SYSTEM



The cabinetry is like furniture in animal hospitals. Clinics and all the practices. It does not merely provide working platforms for preparation, cleaning, scrubbing, etc, also brings great storage space and make all the tools and materials organized.

- The base cabinets off the ground will facilitate the cleaning jobs.
- Bottom cabinets sitting on ground, overhead cabinets and tall cabinetry.
- A vast selection of all the wood colours and textures.
- Many patterns available for the regular opening doors on both overhead and floor standing cabinets.
- All the colours, sizes, accessories, combinations can be tailor made.
- Free of charge 3D designing software.

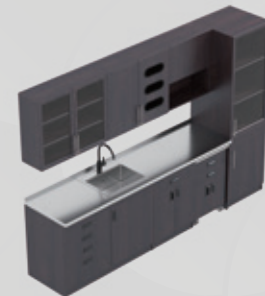

ADVANTAGES OF STAINLESS STEEL



- Easy to clean and no maintenance worry.
- High-end appearance, professional benchmarking hospital style.
- Compared with wooden cabinets, stainless steel will not mold, will not be damp, will not give rise to insects.
- Long service life and durability.



VARIOUS OF MATERIAL AND TEXTURE FOR CHOOSING

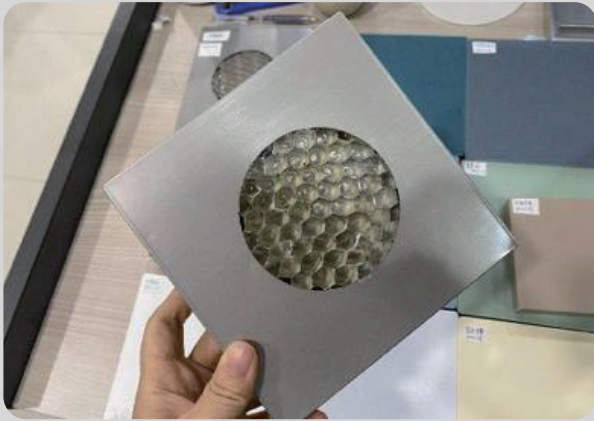

OPTION 1:

SUS201/SUS304 stainless steel basic sheet + aluminum honey comb sandwich

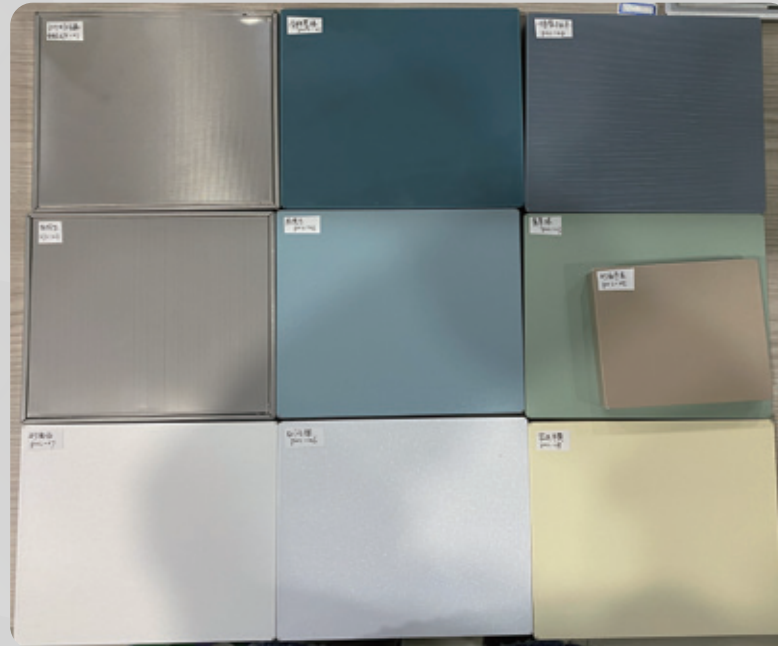
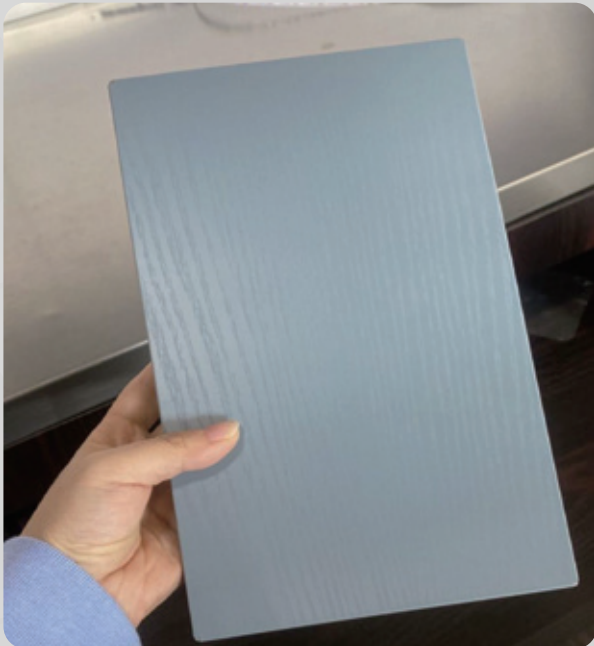

OPTION 2:

SUS201/SUS304 stainless steel basic sheet + aluminum honey comb sandwich + pvc laminate

VARIOUS OF MATERIAL AND TEXTURE FOR CHOOSING



OPTION 3:

SUS304 stainless steel sheets + aluminum honey comb sandwich + engraving pattern and titanium coating, high end solution

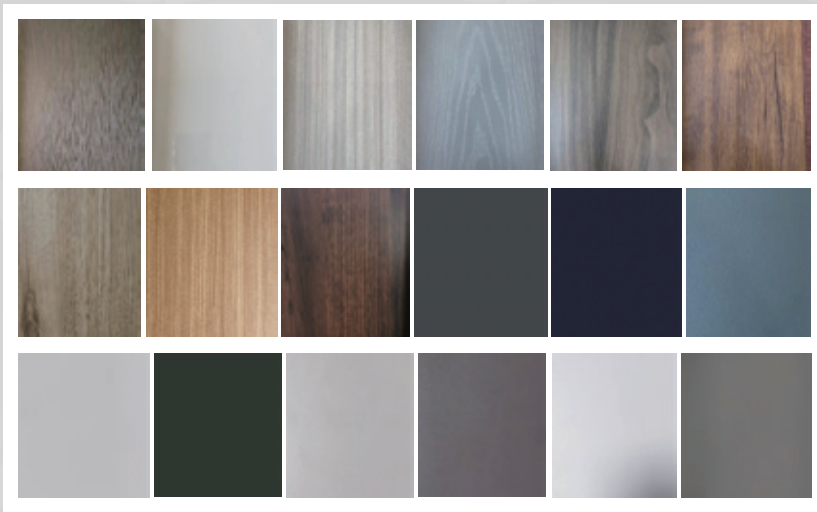

There is a vast selection of all the wood colours and textures, like Oak Antique Cherry, Poplar Yettman Cherry, Oak Fruitwood, Poplar Coffee Bean, Hickory Natural, Hickory TeakMap Boston, Map Fog, Hale Navy, Gentleman's Grey, Sea Salt, Pure White, Mindful Grey, Urbane Bronze, Tricorn Black, etc.

VARIOUS OF COLOR FOR CHOOSING



VARIOUS OF STYLE FOR CHOOSING



Base Cabinet

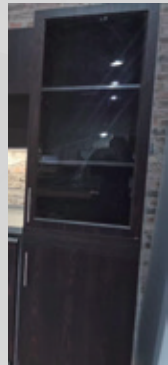

Overhead Cabinet



Wall Mount Cabinet



Mobile Trolley



Tall Cabinet



The Doors of Wall Cabinets

VARIOUS ACCESSORIES FOR CHOOSING

GARBAGE BIN



FAUCET



COUNTERTOP



Washing Basin

Brushed stainless steel

Brushed stainless steel (with sink)

201/304 Stainless Steel sheet in powder coated coating+ aluminum alloy honey comb filling

Arched Flat Panel

Plank

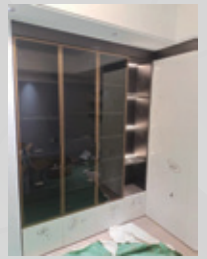
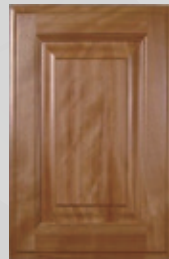

Flat

Arched Raised Panel

Reverse Square

Stainless Steel and Glass/Acrylic

DOOR PANELS

VARIOUS ACCESSORIES FOR CHOOSING

LED LIGHT



DRAWER

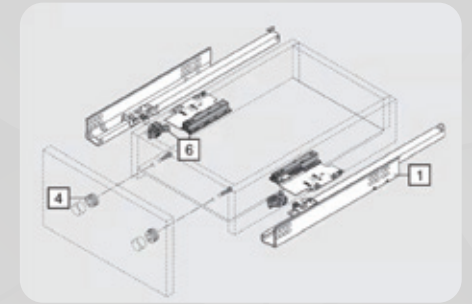

Guiding rail of drawer



Triad full extension, with bumper sliding roller track

Single-layer stainless steel base

HANDLE



Arched Flat Panel



Flat Bow



Traditional Knob



Square Corner Bar



Alloy



Aluminum



Invisible Hidden Concealed



Aluminum base



Double-layer stainless steel base

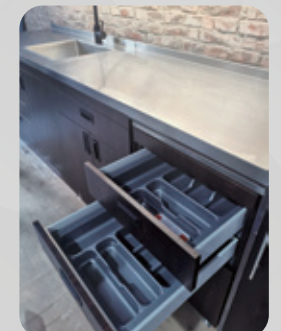

Instrument tray

FINISHED PROJECTS

TYPE A

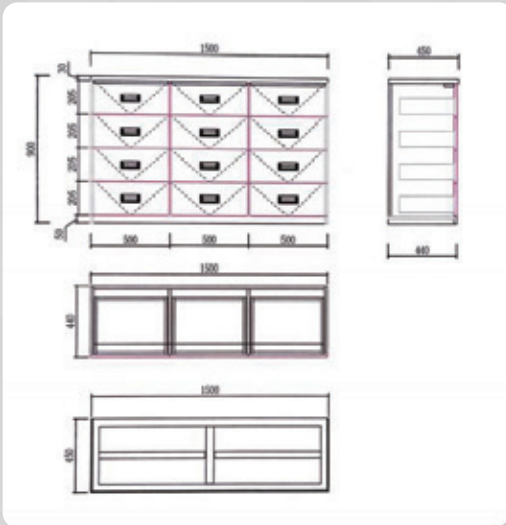

Type A Dimension:

150cm×45cmD×90cmH

Description:

3×4 drawers, 12 in total. Made from White laminated stainless steel panel.

TYPE B

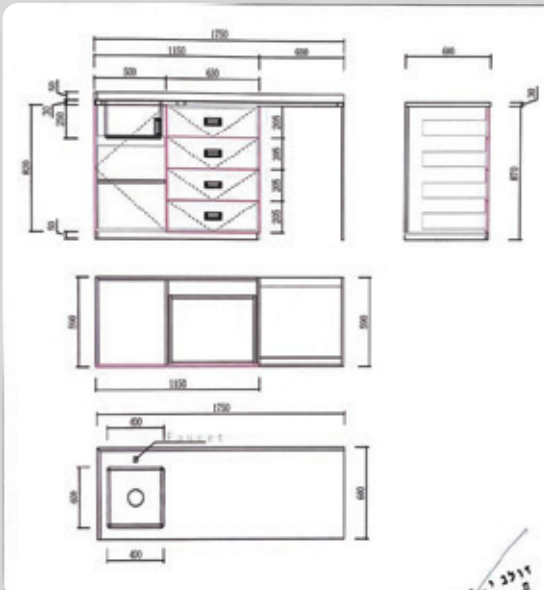

Type B Dimension:

175cm×60cm×95cmH

Description:

With drop-in sink at 40cm×40cm×20cmD and retractable faucet (no infrared) equipped. 4 tiers of drawers is 65cm wide. 60cm on the right hand fully open for fridge location. Made from white laminated stainless steel panel.

FINISHED PROJECTS



Full Dimension:

165"L×12"/24"W×89"H

420cmL×30cm(top)/ 60cm(bottom)W×226cmH

Description:

Made from Brushed Laminated 201 Stainless Steel with aluminium honey comb filling, drawer made from Double Layered Stainless Steel, Counter Top and back panel is made from Brushed 304 Stainless Steel, Golve Cabinet, Mobile Cart, Strip Lights are all included.

FINISHED PROJECTS

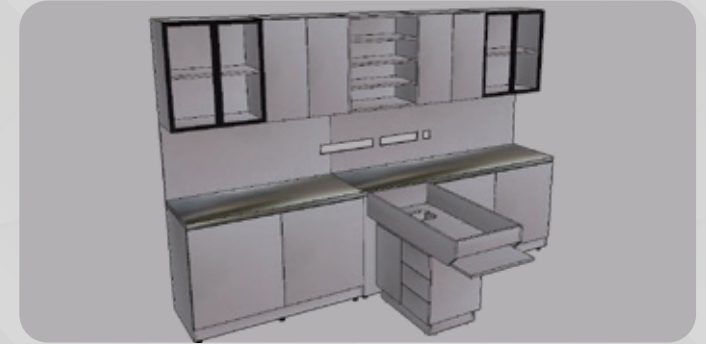

Full Dimension:

135"L×12"/ 24"W×90"H

344cmL×30cm(top)/ 60cm(bottom)W×227cmH

Dental Table: 48"L×24"W×36"H

122cmL×61cmW×91.5cmH

Description:

Made from Brushed Laminated 201 Stainless Steel with aluminium honey comb filling, Counter Top and back panel is made from Brushed 304 Stainless Steel, Strip Lights, 2 unit Sink and 2 kit Faucet, 1unit Dental table are all included.

FINISHED PROJECTS

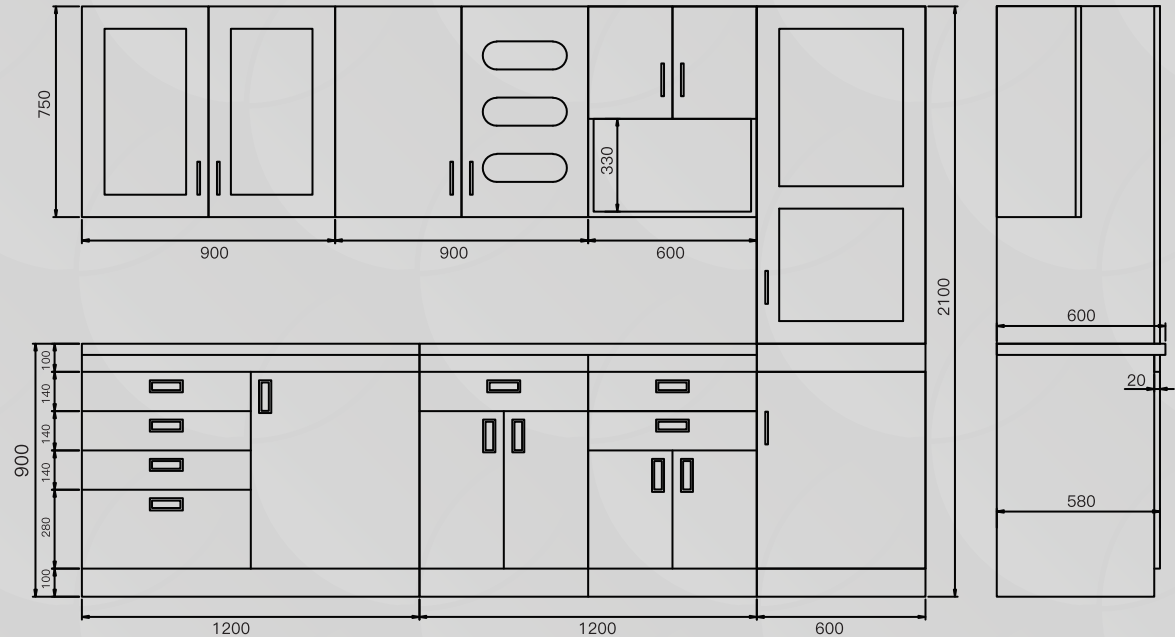

Full Dimension:

118"L×24"W×83"H

300cmL×60cmW×210cmH

Description:

Made from Laminated 201 Stainless Steel with aluminum honey comb filling, PVC surface, drawer made from Double Layered Stainless Steel, CounterTop made from Brushed 304 Stainless Steel, Glove Cabinet, Mobile Cart, Sink with Faucet kit, Strip Lights are all included.



FINISHED PROJECTS



CUSTOMIZATION PROCEDURE

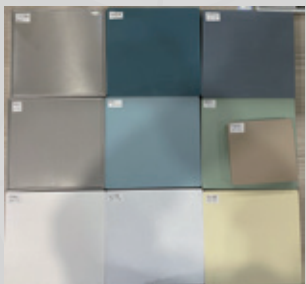

DRAWING CONFIRMATION

We will offer layout for your first confirmation.

INSPECT GOODS

We will provide video and photos for your final confirmation.

PACKING PICTURE

Packaged in modules, easy to install, no need to assemble piece by piece.

MATERIAL AND COLOR

You can choose the material and color you want.

PRODUCTION

It can be completed in 28 days, providing real object display.

